

The Missoula Public Library

406-721-2665

And the Library Telescope Program of

The Western Montana Astronomical Association

Orion StarBlast 4.5" Telescope

INSTRUCTION MANUAL



WARNING: Never look directly at the Sun through your telescope or its finder scope — even for an instant — as permanent eye damage could result. Do not point the telescope at the Sun, as parts will melt! Children should use this telescope only with adult supervision.

The Western Montana Astronomical Association

The WMAA is an educational organization that promotes public awareness of astronomy. We hold public star parties, demonstrations, presentations, and discussions, all free of charge.

Visit <http://missoulasky.org> for more information about club events and contact information. Our meetings are typically the 2nd Friday of every month either at the Target Range School Library or the Montana Natural History Center's Native Garden Plant Classroom. See the website for details about upcoming meetings.

The checkout program and telescope are modeled after a similar one in New Hampshire. Visit <http://nhastro.com/ltp.php> for more details on our inspiration

The WMAA partially funded this telescope and is providing the library with ongoing help in public education about astronomy and maintenance of this telescope.

We hope you enjoy using it!

Nick Wethington - WMAA Library Telescope Coordinator astrogentleman@gmail.com 2

Telescope Parts

- 1) Eyepiece (Zoom 8 to 24 mm)
- 2) EZ Finder with AA battery box
- 3) Telescope tube
- 4) Focuser
- 5) Tube Clamp
- 6) Altitude Clamp
- 7) Mirror Assembly
- 8) Support
- 9) Handle
- 10) Eyepiece rack (removed)

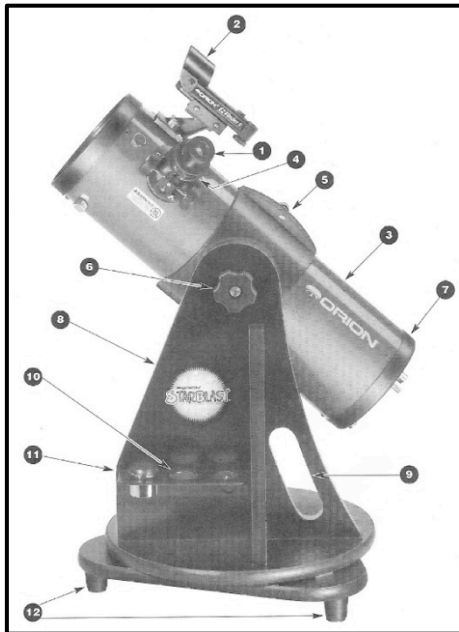

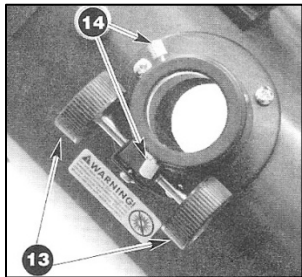

Focuser Details

- 13) Focus wheels
- 14) Eyepiece securing screws (replaced with hex screws)

EZ Finder Details

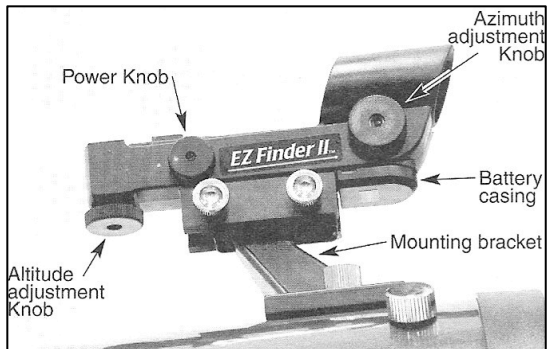

Transporting the Telescope

The telescope comes in a hard carrying case to minimize damage while transporting the telescope and bundle accompanying items along with it. It is easy to lift with one person, though two can be helpful to navigate it through doors and into cars. Grab both handles securely and ensure that the clasps on the front of the case are closed completely before lifting. The picture below illustrates how the telescope should be fitted into the case. Please flip the telescope tube over on the mount so that the eyepiece is pointing downward into the case (don't bind up the strings that attach the caps to the mount). Put the telescope into the case as shown, close the lid gently, and turn the clasps clockwise to lock the lid shut. The case should fit easily into the back seat of a car or the trunk.



Care and Maintenance

Aligning the Mirrors: Again, please don't. If it seems that the telescope is in need of adjustment, please tell a librarian.

Fog on the mirrors and eyepieces: One of the odd things that happens when star gazing is that dew forms on pretty much everything (and everyone). The big mirror is tucked safely down at the bottom of the telescope, and so it does not get much dew on it. Eyepieces, however, often have dew form on them, making them useless until they warm up and dry out. If the eyepiece fogs up, wrap your hands around it for a few moments. As it warms up, the fog should disappear. Please don't wipe the lens with a tissue or cloth as it has special coatings on it that could be damaged if you do. Please ask people to not touch the lens... ever.

The Eyepiece chart on the telescope shows what magnification you will have for each setting of the Zoom Eye piece. The "True Field" describes the width of the image in the eyepiece. A full Moon is 30 minutes of a degree (or $\frac{1}{2}$ of a degree) wide, so you could fit about 4 full Moons in the field of view when using the 8mm setting. Change the zoom setting until your target fits the eyepiece the way you like. You will have to tweak the focus.

Getting Started

Please read the instructions and practice with the telescope inside before you take it out in the dark. The image will be much better if you let the telescope cool down to air temperature before you start observing.

This is a “Push-to” telescope. Once you find what you are looking for, you can either watch the object move through your “field of view” (what you see through the eye piece) and then reposition the telescope, or keep pushing the scope to hold the object in the center of the eyepiece. Objects appear to move across the field of view faster at higher magnifications. This is because the field of view becomes narrower.

Like many reflector telescopes, the image in the eyepiece is upside-down. When looking at star charts you will have to keep this in mind. The Moon map on this telescope is “flipped” so it matches what you see in the eyepiece.

Do You Wear Eyeglasses? If so, you will probably be able to observe with your glasses off by just refocusing the telescope to your unaided vision. If your eyes are astigmatic, images will probably appear best with glasses on. This is because a telescope’s focuser can accommodate for nearsightedness or farsightedness, but not astigmatism.

This is important enough to say again:

WARNING: Never look directly at the Sun through your telescope or its finder scope — even for an instant - as permanent eye damage could result. This is one of the few really bad things you can do to yourself twice. Young children should use this telescope only with adult supervision.

Focusing the Telescope: Try out the telescope during the day when you can see what you're doing. Remove the dust caps from the eyepiece and telescope tube.

The “power” of a given telescope depends upon the eyepiece you use. This scope has a zoom eyepiece. Always start by using the telescopes' lowest-power (turn the body of the zoom so the pointer is at “24”) to locate and center an object. Low magnification shows a larger area of sky in the eyepiece, making finding and centering an object much easier.

With the eyepiece adjusted for low power (24 mm), aim the telescope in the general direction of an object at least 1/4-mile away. Slowly rotate the focus wheels until the object comes into sharp focus. Go a little bit beyond sharp focus until the image starts to blur again, then reverse the rotation of the knob, just to make sure you've hit the exact focus point. When focusing on stars, bring them to as small a point as possible.

Many “deep-sky” objects are big, but dim. Low magnification will be better for them. Once you’ve centered an object in the eyepiece, you can switch to a higher magnification by twisting the zooms’ barrel towards the “8”. This is recommended for small and bright objects, like planets and double stars. The Moon also takes higher magnifications well. You may have to refocus a little after changing power.

If you find that it’s awkward to put your eye up to the eyepiece, you can rotate the telescope tube by loosening the knob on the tube clamp and moving the telescope tube until the focuser is in a convenient position. Be sure to tighten it again!

You may find that the telescope tube is either too hard to move or does not stay in place. Use the altitude adjustment tension knob (it holds the telescope to the upright part of the base) to find the right level of tension.

Operating the EZ Finder

A “finder scope” helps you point the scope, rather like a rifle sight. The **EZ Finder** works by projecting a tiny red dot onto a screen mounted in the front of the unit, so that when you look through the screen, the red dot will appear to float in space. Turn the power knob clockwise until you hear a “click” indicating that power is on. With your eye positioned near the rear of the telescope, look through the EZ Finder with both eyes open to see the red dot. The intensity of the

dot can be adjusted by turning the power knob. Use the dimmest possible setting that allows you to see the dot without difficulty. When the EZ Finder is properly aligned with the telescope, an object that is centered on the EZ Finder's red dot should also appear in the center of the telescope's eyepiece. Checking the alignment of the EZ Finder is easiest during daylight. Aim the telescope at a distant object, such as the top of a telephone pole or chimney and center it in the telescope's eyepiece. Now, turn the EZ Finder on and look through it. The object should appear near or under the red dot. **If not:** Without moving the telescope, use the EZ Finder's left/right (azimuth) and up/down (altitude) adjustment knobs to position the red dot on the object in the eyepiece. If the red dot is centered on the object in the eyepiece, you're done!

The finder scope has a battery pack attached to the telescope. At the end of your observing session, be sure to turn the power knob counterclockwise until it clicks off.

What to Expect

Depending upon what is in the sky; Planets will look small, but you might be able to see cloud bands on Jupiter or the rings of Saturn. Craters on the Moon will be clear and numerous, the waxing and waning of Venus should be visible, and many bright deep-sky objects will fill the eyepiece. Don't expect to see color as you do in NASA photos as our eyes are not sensitive enough

to see color in deep-sky objects, except in a few of the brightest ones. Remember that you are seeing these objects using your own eyes! Each session with your telescope will be a learning experience. Each time you work with the telescope, it will get easier to use, and stellar objects will become easier to find.

Objects to Observe:

The Moon is one of the easiest and most interesting targets to view with your telescope. Lunar craters, “seas”, and even mountain ranges can all be clearly seen from a distance of 238,000 miles away! With its ever-changing phases, you’ll get a new view of the Moon every night it’s up. Make sure to observe the Moon when it is well above the horizon to get the sharpest images. The best time to observe is during a partial phase, that is, when the Moon is *not* full. During partial phases, shadows are cast on the surface which reveals more detail, especially right along the border between the dark and light portions of the disk (called the “terminator”). Use the Map on the telescope tube to find the major craters and features.

If the Moon is too bright, or you want a bit more contrast, remove the small black plug from the dust cover and put the cover back on the telescope. This is called “stopping down” and reduces the light hitting your eye. Be sure to replace the plug in the cap when putting the telescope back in its case.

The Planets: They do not stay at “fixed” locations like the stars do. To find them you should refer to Sky Maps (www.skymaps.com), or to charts published monthly in *Astronomy*, *Sky & Telescope*, or other astronomy magazines and web sites. Venus, Jupiter, and Saturn are the brightest objects in the sky after the Sun and the Moon. The planisphere can also be used to find them.

Stars: Even powerful telescopes cannot magnify a star to appear as more than a point of light. You can, however, enjoy the different colors of the stars and locate many pretty double and multiple stars. (Look at the middle star in the handle of the Big Dipper, Mizar. It is really two stars very close together.) Being able to see the two stars separate is called “Star Splitting”. The gorgeous two-color double star, Albireo, in Cygnus is a favorite. Defocusing a star slightly can help bring out its color.

Deep-Sky Objects: Under dark skies, you can see lots of fascinating deep-sky objects, including nebulas, star clusters, and a variety of different types of galaxies.

Most deep-sky objects are very faint, so it is important that you find an observing site well away from light pollution. Take plenty of time to let your eyes adjust to the darkness. Do not expect these subjects to appear like the photographs you see in books and magazines; many will look like dim gray smudges. As you become more experienced and your observing skills get sharper, you will be able to ferret out more and more subtle details and structure.

Deep-Sky Objects, also referred to as “faint-fuzzies” are often hard to find at first. They are worth the effort, being some of most wonderful things in the night sky. Many constellations have numerous objects hidden within them that are only visible with a telescope or binoculars. Pay particular attention to objects with a “Messier Number”, like The Orion Nebula (M-42) and the Andromeda Galaxy (M-31). First published in 1774, Charles Messier made this list to help observers identify objects that might be mistaken for comets. Messier’s list includes some of the brightest and most attractive deep sky objects observable from the northern hemisphere

Star Clusters are particularly pretty, usually bright and easy to see. Note that some Messier Objects are very faint, and will take a while to find and see. A few are very dim, but may seem to appear like magic when you look at them “out of the corner of your eye”. This is called “Averted Vision” and works well when looking at very dim objects.

Star Hopping: This term describes how one uses a star chart to find objects too dim to see without a telescope. You likely already know how to do this, if you can find the North Star by following the “pointer stars” of the Big Dipper. To find a deep sky object, look for a pattern of stars that can act as landmarks for it. For example: To find the Pinwheel Galaxy, M 101, look for the last two stars of the Big Dipper’s handle. They make the base of a triangle that has the M 101 at the top.

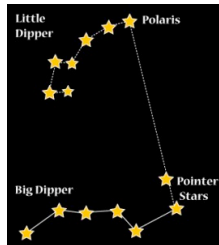

You can also try a low-power (24 mm) scanning of the Milky Way: just cruise through the “star clouds” of our galaxy. You’ll be amazed at the rich fields of stars and objects you’ll see!

When to go observing:

“Seeing” and Transparency: Atmospheric conditions vary significantly from night to night.

“Seeing” refers to the steadiness of the Earth’s atmosphere at a given time. In conditions of poor seeing, atmospheric turbulence causes objects viewed through the telescope to “boil”.

In conditions of good seeing, star twinkling is minimal and images appear steady in the eyepiece. Seeing is best overhead, worst at the horizon. Good “transparency” is especially important for observing faint objects. Transparency is judged by the magnitude of the faintest stars you can see with the unaided eye (Mag.1 is very bright, 2 is dimmer, and so on... 4th magnitude or fainter is desirable).

Looking at the Little Dipper will show you how good the viewing is. If you can see all the stars, you are doing pretty well. Be sure to wait until your eyes adapt to the dark

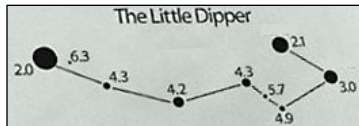

One more time, and with Feeling! WARNING: Never look directly at the Sun through your telescope or its finder scope — even for an instant — or permanent eye damage could result. Do not point the telescope at the Sun, as parts will melt! Children should use this telescope only with adult supervision

If you go to <http://cleardarksky.com/c/MissoulaMTkey.html?1>, you will find the “Clear Sky Chart” for Missoula. The chart is a time line for weather. If you click on the chart, it will link to a detailed explanation. You will also find links to other charts. Pick the closest one to you for local weather conditions. For example, let’s use the NHAS chart: The first 4 bars are the most important: Is it cloudy? How clear is the sky? What is the “Seeing”, and finally, how dark is it? The deeper blue the squares are, the better. In the chart below, both Thursday and Friday nights look clear and relatively great for observing. The later at night, the better and darker it will be. Either night would be great to borrow the telescope for!

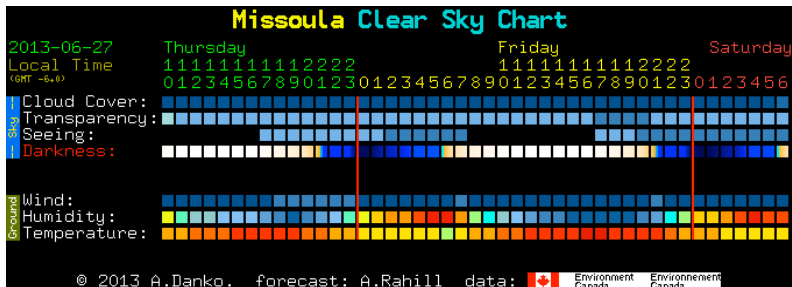

The Field Guide and Planisphere

The telescope is accompanied by both The National Audubon Society Field Guide to the Night Sky and a planisphere. These are both very helpful tools to use to find out what's in the sky no matter what time of year. Don't feel as if you have to read the whole book, though, to use or appreciate the telescope and night sky. The best way to learn the night sky is to go out and look at it! The planisphere is a handy way to find out what constellations are up at night by showing you the brighter stars that should be visible from your location. A full set of instructions is on the back of the planisphere, and once you get used to how to use it learning constellations will be easy.

Other Reference Materials

Of course, there are many other reference materials both at the library and online to help you learn more about astronomy. Ask a librarian about books that may help you learn more about astronomy. If you are looking for planetarium software to use on your computer, a great free one to download is Stellarium. It works with almost any computer, is free to download and is one of the easiest to learn how to use. See www.stellarium.org for more information.

Finally, if you find yourself either confused about the telescope and its operation or extremely enthusiastic about learning more about astronomy, get in touch with the Western Montana Astronomical Association at www.missoulasky.org.